

HRV : Hydraulic Reversing Vertical Gears
HRH : Hydraulic Reversing Horizontal Gears



HRV Series

Single stage, reversing gear units with vertical offsets. Standard horsepower ranges are from 800 hp to 5000 hp and standard ratios are from 3.0:1 to 7:1.

HRH Series

Single stage, reversing gear units with horizontal offsets. Standard horsepower ranges are from 800 hp to 5000 hp and standard ratios are from 3.0:1 to 7:1.

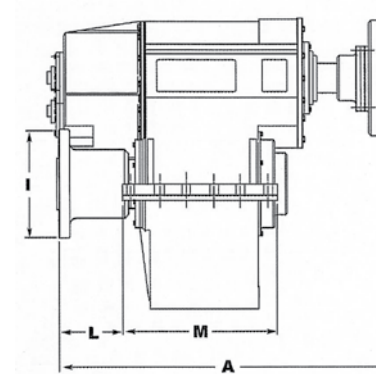
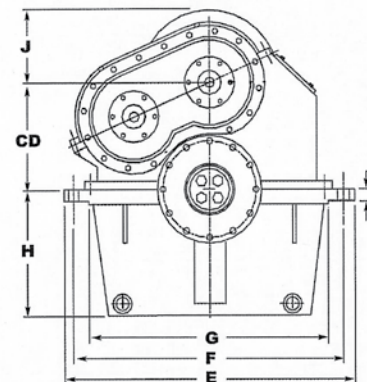
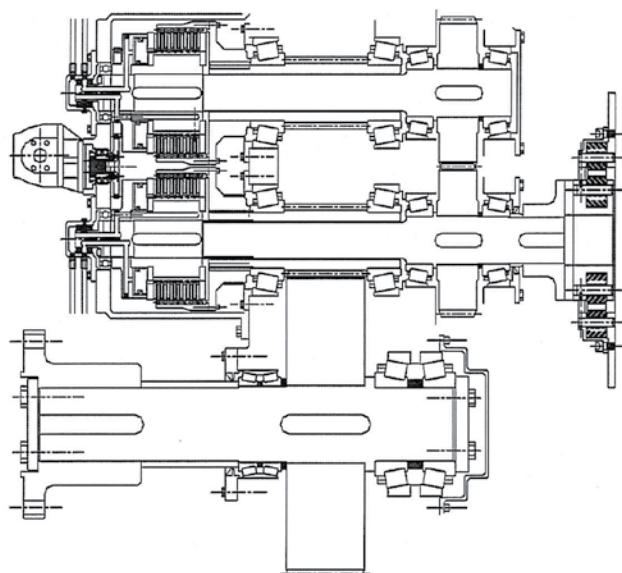

HRV

Model	HP	RPM	Ratio	A	CD	D	E	F	G	H	I	J	L	M
HRV-1711	1200/	1200/	3.0/	59.15	16.562	2.00	46.00	43.50	34.50	16.18	17.00	13.25	21.30	26.00
	1600	1600	5.1:1	1502	421	50	1168	1105	876	411	432	337	541	660
HRV-2116	1800/	900/	3.0/	89.87	20.87	2.00	64.00	63.00	46.50	24.00	19.00	14.50	22.00	28.00
	2500	1800	5.5:1	2283	530	50	126	1600	1181	610	483	368	559	711
HRV-2411	2000/	900/	3.0/	89.87	24.40	2.00	66.00	63.00	48.00	26.91	19.00	15.00	22.00	28.00
	2800	1800	7.0:1	2283	620	50	1676	1600	1219	684	483	381	559	711
HRV-2816	2400/	900/	3.0/	89.87	27.56	2.00	66.00	63.00	48.00	26.91	18.00	15.00	24.00	32.00
	3100	1800	7.0:1	2283	700	50	1676	1600	1219	684	457	381	610	813
HRV-3216	2800/	900/	3.0/	92.00	31.50	2.50	80.00	74.00	62.00	30.00	24.00	16.00	27.00	36.00
	3600	1800	7.0:1	2337	800	63	2030	1880	1575	762	610	406	685	915
HRV-3616	3200/	900/	3.0/	102.00	36.00	2.50	88.50	76.75	64.50	30.50	26.00	18.75	27.00	40.00
	4200	1800	6.5:1	2591	914	63	2248	1949	1638	775	660	476	685	1016
HRV-4016	3600/	900/	3.0/	107.00	40.00	3.00	92.25	78.00	66.25	32.75	28.50	20.00	28.25	44.00
	5000	1800	6.0:1	2718	1016	76	2343	1981	1683	332	724	508	718	1118

Gear Elements

All HRV/HRH series gear elements are fully inspected carburized, hardened and precision ground. These high quality gears are excellent for high speed diesel engines and large reduction ratios. The high accuracy of the gears results in very low noise.

Clutches

These heavy duty hydraulic clutches are specifically designed for Haley marine propulsion gears. These externally mounted clutches allow up to 100% larger clutch area than our nearest competitor's gear, while allowing better cooling with easy accessibility for repair or removal.

Bearings

All bearings are current production of tapered roller or spherical roller bearings manufactured in the U.S. by leading manufacturers.

Gear Cases

Gear cases are fabricated in our Greenville facility by experienced and skilled fabrication engineers. New standard cases as well as special cases can be completed in a few weeks.

Lube Systems

Oil pressure flow from precision gear pumps, with dual fine mesh cleanable filter. Suitable coolers of any type are available.

Controls

The latest versions of clutch and system controls are available in both electric and pneumatic activation for standard slip or dynamic positioning systems.

Engineering Assistance

CAD engine and gear installation drawings, lube, and cooling system drawings. Torsional analysis or mass elastic data available. Start up and service engineers available at all times.

Special center distance available upon request. Consult engineering department for installation drawings and/or for selection of torsional vibration damping couplings and shaft brake systems.

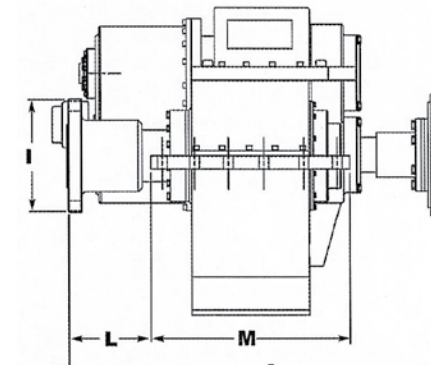
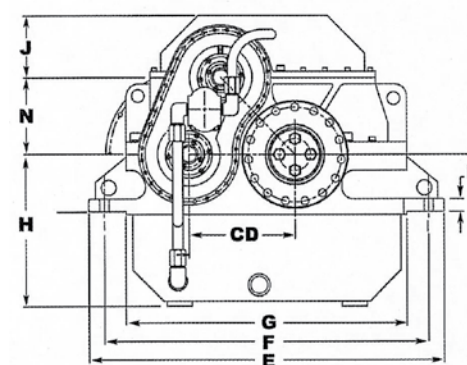

HRH

Model	HP	RPM	Ratio	A	CD	D	E	F	G	H	I	J	L	M	N	O
HRH-1711	1200/	1200/	3.0/	82.00	16.560	1.50	48.00	45.75	42.50	24.25	16.75	14.50	15.50	40.75	13.75	9.75
	1600	1600	5.1:1	2083	420	38	1219	1162	1080	616	425	368	394	1035	349	248
HRH-2116	1800/	900/	3.0/	89.87	20.875	2.50	58.00	62.87	54.25	26.25	17.50	15.12	17.50	42.25	15.5	9.75
	2500	1800	5.0:1	2283	530	63	1473	1597	1378	665	444	385	444	1073	394	248
HRH-2411	2000/	900/	3.0/	89.87	24.504	2.50	62.00	65.75	56.75	28.50	19.25	15.12	17.50	42.75	16.75	9.75
	2800	1800	5.5:1	2283	622	63	1575	1670	1441	724	489	385	445	1086	425	248
HRH-2816	2400/	900/	3.0/	89.87	26.87	2.50	75.00	69.00	60.00	32.75	22.50	15.25	18.50	44.25	18.38	9.75
	3100	1800	5.5:1	2283	682	63	1905	1753	1524	832	571	387	470	1124	467	248
HRH-3216	2800/	900/	3.0/	92.00	31.50	2.50	87.50	81.50	75.00	35.00	25.00	15.75	19.00	45.00	19.00	11.00
	3600	1800	5.75:1	2337	800	63	2222	2070	1905	889	635	400	483	1397	483	279
HRH-3616	3200/	900/	3.0/	102.00	36.00	3.00	110.00	101.00	90.00	37.00	28.00	17.75	19.00	55.00	22.00	15.00
	4200	1800	6.25:1	2591	914	76	2794	2565	2286	940	711	451	483	1397	559	381
HRH-4016	3600/	900/	3.0/	107.00	40.00	3.00	112.00	107.00	90.00	39.00	30.00	19.50	20.00	56.00	23.00	16.00
	5000	1800	6.5:1	2718	1016	76	2845	2718	2286	990	762	495	508	1422	584	406